

## Redundancy Schemes for Frequency Converters

by Andrea Franz, A.G. Franz LLC

### Agile Frequency-Converters

At satellite earth stations numerous satellite transponder signals are being directly received from the satellites and downconverted for further processing at intermediate frequencies, or they are upconverted from the intermediate frequencies to be sent to the satellites. Typical applications include X-, C-, Ku- and Ka-Band satellite payloads.

### Redundancy

In order to ensure highest reliability and availability for their satellite customers, earth station operators apply redundancy schemes for the up- and down-link equipment chains. Depending upon the system deployment reliability and availability requirements, operational complexity as well as budget and space constraints, different redundancy configurations are deployed. Each configuration requires additional equipment or component parts to implement the chosen redundancy scheme.

In the following discussion the term “detected fault” is defined as either a failure of the unit, or a catastrophic (power) failure.

### 1-for-1 Passive Redundancy

This approach is the simplest and least expensive implementation. The configuration relies entirely on the internal control capability of the converters: any two identical converters will operate as a 1-for-1 passive redundant pair, with no other equipment except for a single interconnecting CANBUS® control lead, two power splitters /combiners and RF cables to connect the units in parallel. (see Fig.1)

Both converters operate continuously, performing their conversion function on the incoming signals, but only one unit enables its output. Each converter continually provides status to the other unit’s 1-for-1 control logic. There is no pre-assigned master and slave unit. Change-overs are minimized, i.e. a unit disabled due to a reported fault, will remain disabled even if it returns to the non-alarm state.

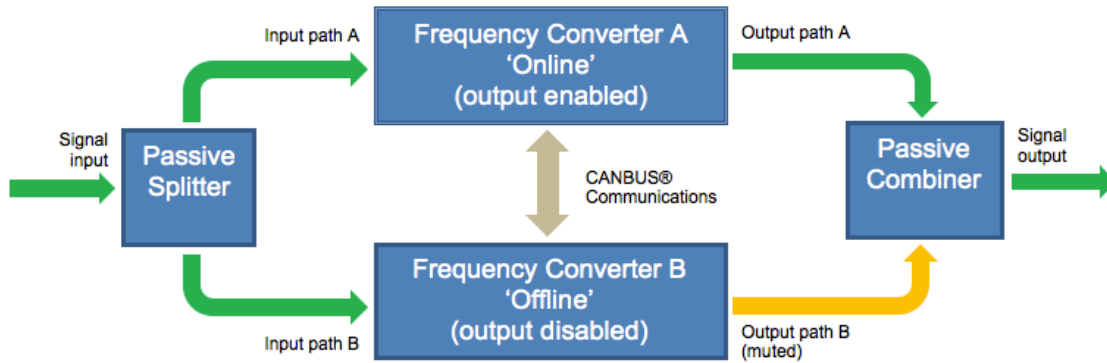

Fig.1: 1-for-1 Passive Redundancy

In the event of a catastrophic fault, such as a power supply disconnection etc., the control circuitry (which is distributed between the two units) will automatically disable the faulty unit and enable the operational unit.

The biggest disadvantage of such a configuration is that it includes passive two-way splitters & combiners, each with a theoretical 3dB loss, so an associated overall loss of typically 8dB (does not include converter gain) can be expected through the system which will typically be higher than on a traditional co-axial 'switched redundant' system, resulting in signal loss that may require additional gain to compensate.

### 1-for-1 Redundancy with an External Switching Unit

Any two identical converters will operate as a 1-for-1 redundant pair, without the need for an additional controller. All that is required is a switch unit with all necessary interface cabling. UpConverter systems require a unit comprising an input IF splitter and an RF coaxial switch to switch the output. (see Fig.2) DownConverter systems require a unit comprising an input RF coaxial switch and an IF combiner at the output. (see Fig.3)

Both converters monitor the alarm status of each other and control the output coaxial switch, ensuring that the online converter is always connected to the output. If the online converter develops an alarm condition, the standby converter will assume master control and initiate switching, routing itself to the output.

Change-overs are minimized, i.e. a unit taken off line due to an alarm, will remain off-line even if it returns to the non-alarm state. If it does return to the non-alarm state then it will act as the standby unit.

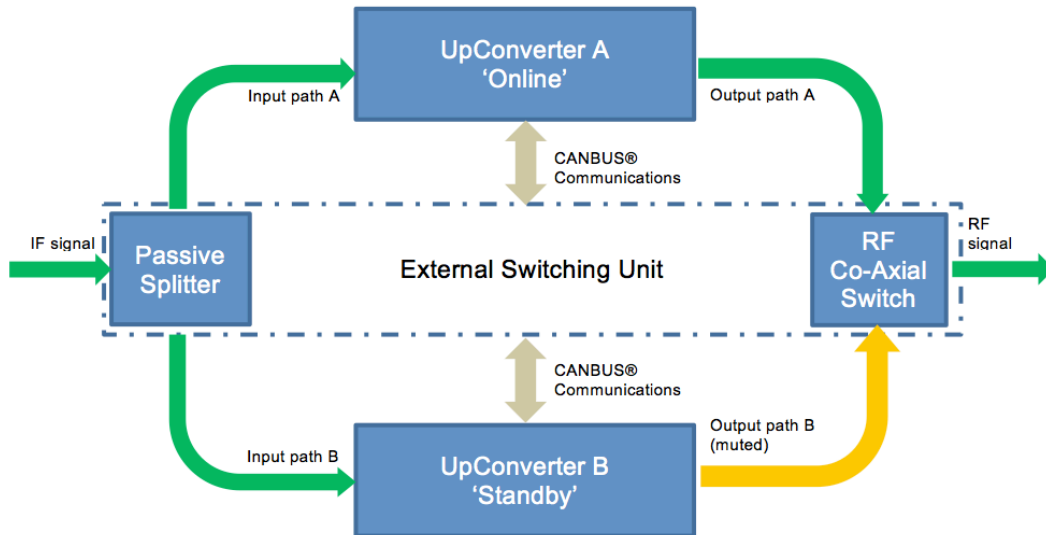

Fig.2: 1-for-1 Redundant Upconverter System with External Switching Unit

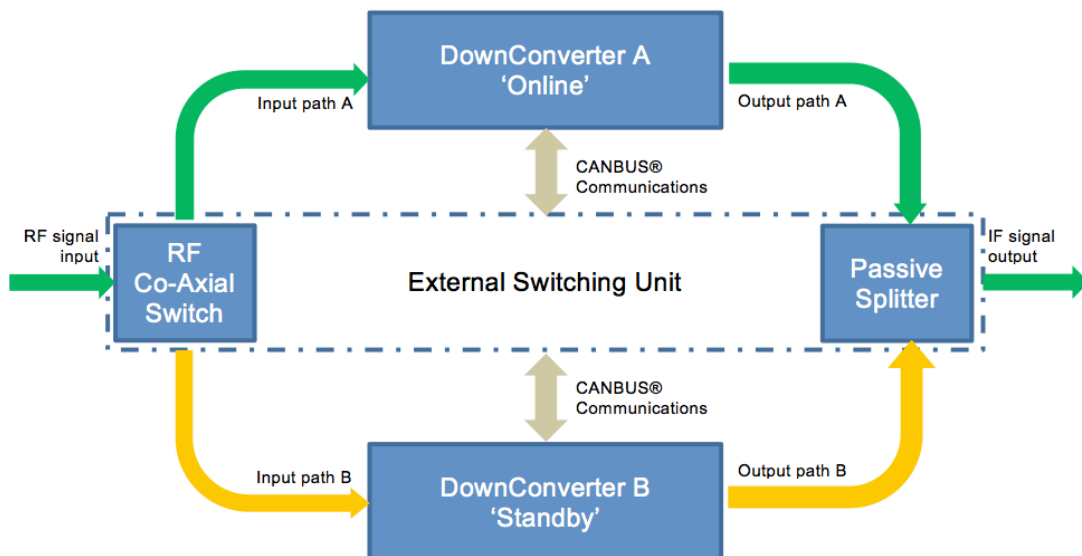

Fig.3: 1-for-1 Redundant Downconverter System with External Switching Unit

Although an external unit containing the switching and splitting/ combining parts is required, this is still a very cost effective solution as it utilizes the Converter control system. It is very simple to set up and the biggest advantage of this hybrid system of passive combiners/ splitters and active switches is that the loss is reduced to typically 5dB (does not include converter gain) through the system.

## 2-for-1 Redundancy with an External Switching Unit

Similar to the previous 1-for-1 configuration, an external switching unit is used that is now controlled by two on-line units, switching the off-line unit into the appropriate path. (see Fig.4 and Fig.5)

All converters monitor the alarm status of the other units and control the coaxial switch positioning. If an online converter develops an alarm condition, the standby converter will assume master control, configure itself to replicate the appropriate online unit and initiate switching, routing itself to the appropriate output. Priority can be set, so that if there is a second failure the higher priority path will remain operational.

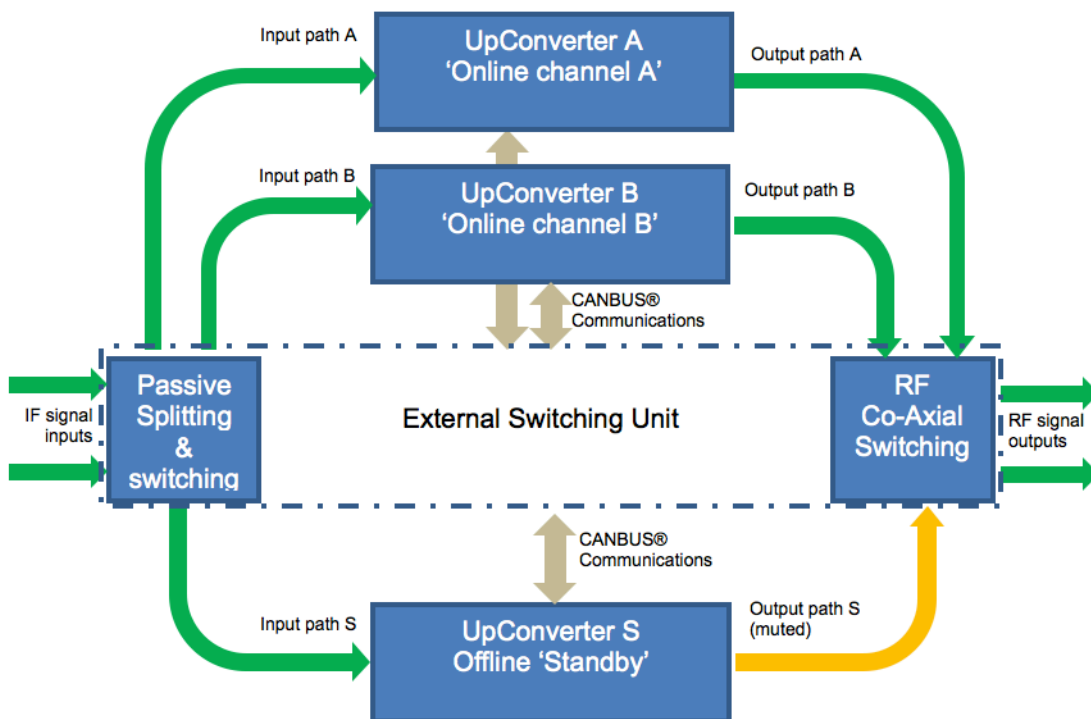

Fig.4: 2-for-1 Redundancy Upconverter System with External Switching Unit

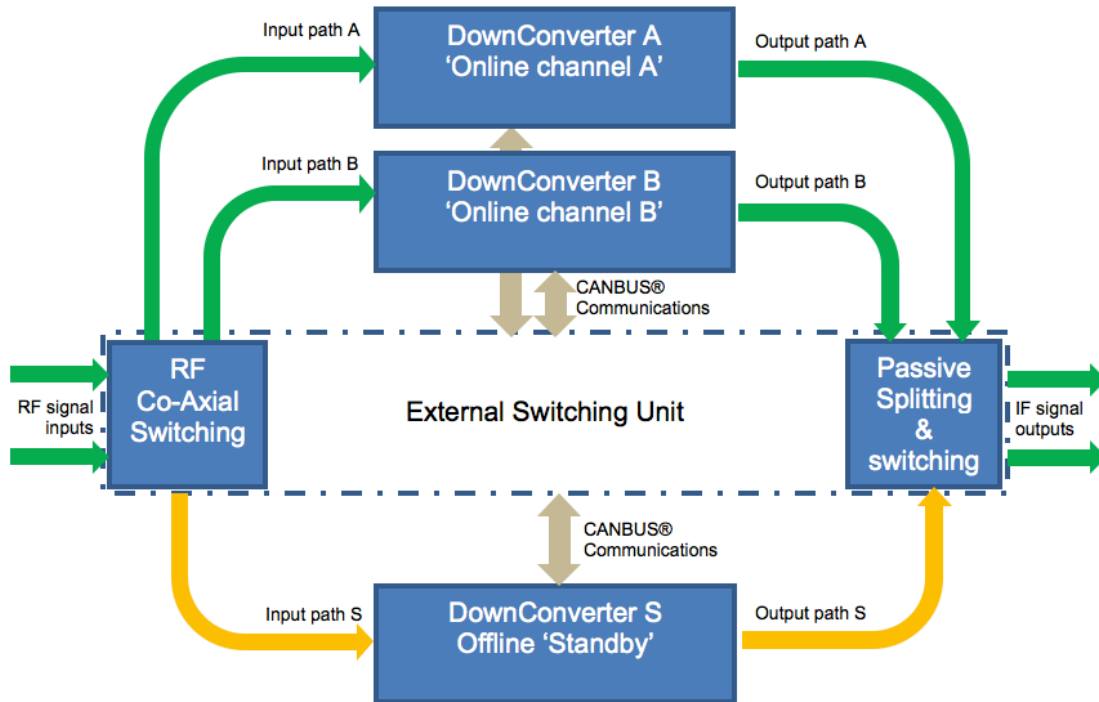

Fig.5: 2-for-1 Redundancy Downconverter System with External Switching Unit

Generally for any 2-for-1 system, reliability/ availability of each path is slightly reduced when compared to two 1-for-1 systems, since in the case of a double failure there is no redundant unit available for the second path.

Due to the additional channel switching, the loss is greater than with a 1-for-1 system, and would typically be 8dB (does not include converter gain) through the system.

This configuration is available with priority path setting, and can be partially populated (with only two converters), to behave like a 1-for-1 system.

### Redundancy with a Stand-Alone External Control & Switching Unit

Traditional implementations utilize external, stand-alone, fully co-axial switched redundancy units. Additionally the switch units can be used for either Up or DownConverters. (see Fig.6)

These external control & switching units typically are available for manual or automatic mode, depending on the capability to automatically configure the gain and frequency settings of the offline converter unit to replicate the online converter at the time of change-over. This is performed via the CANBUS® interface.

Changeovers are minimized, i.e. a unit taken off line due to an alarm, will remain off-line even if it returns to the non-alarm state. If it does return to the non-alarm state then it will act as the standby unit.

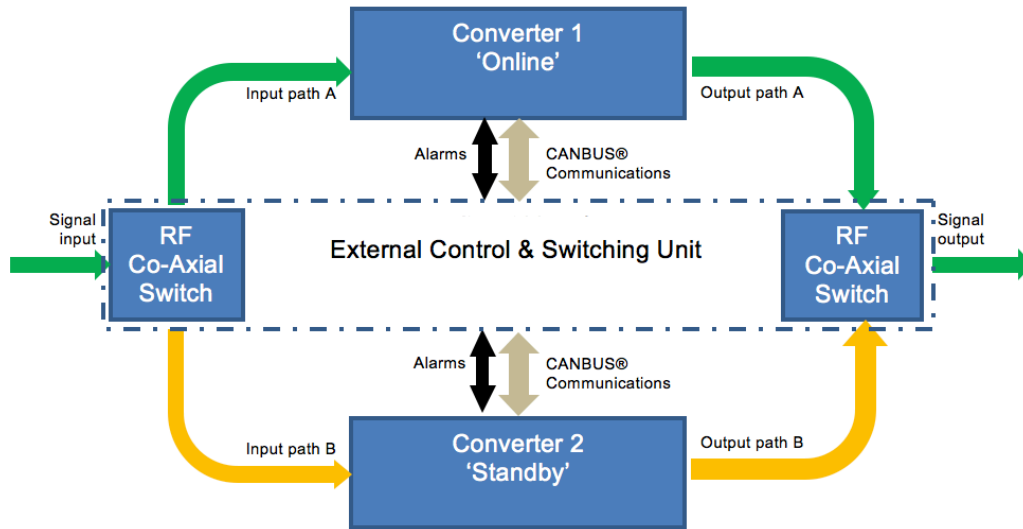

Fig.6: 1-for-1 Redundancy with a Stand-Alone External Control Unit

As co-axial switches are used for both input and output switching, the biggest advantage of these configurations is the minimized loss, which can be typically 3dB (does not include converter gain) through the system.

In a 2-for-1 system the priority can be set so that in the event of both online converters becoming faulty, the standby unit is switched to the highest priority path. (see Fig.7)

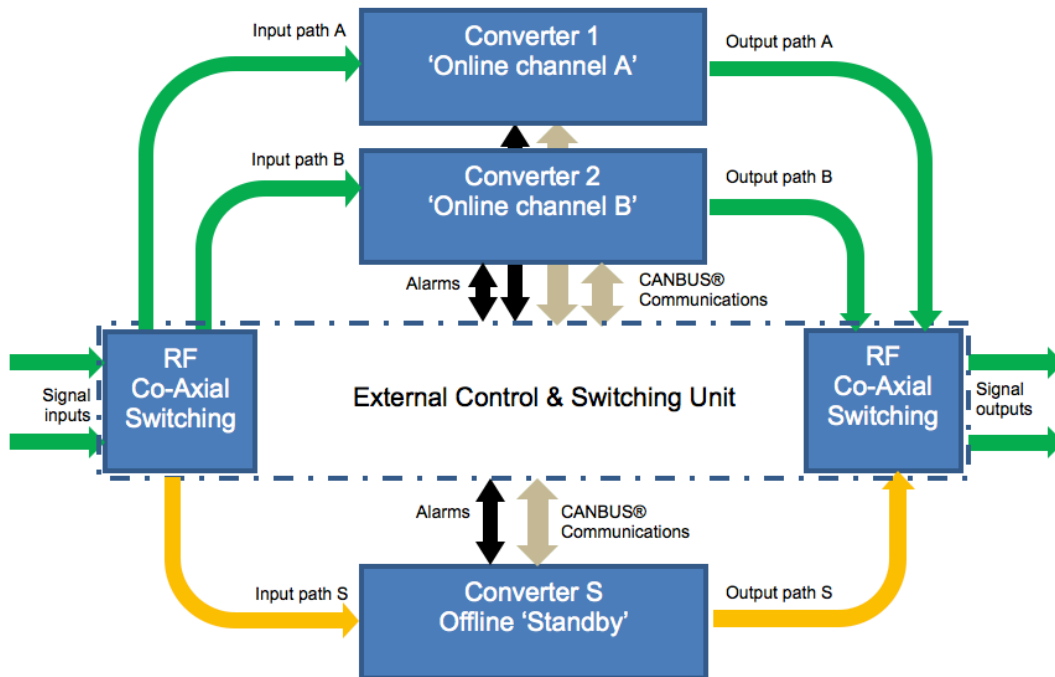

Fig.7: 2-for-1 Redundancy with a Stand-Alone External Control Unit

For a 2-for-1 redundant system the expected path loss (not including converter gain) is typically 5dB through the system.

### **n-for-1 Redundancy with a Stand-Alone External Control & Switching Unit**

Similar to the 2-for-1 configuration above, systems can be implemented for a range of n-for-1 switching units. The separate control and switching units are typically modular in a larger-than-1RU chassis and can be either partially populated to suit the exact number of ways required, or fully populated to allow for future expansion by simply adding converters, as required.

### **Summary:**

Peak Communications offer these flexible redundancy schemes described above for their P7000 series converters, a next generation fully synthesized combined L-Band Up and DownConverters. The P7000 converters provide a very efficient solution for systems requiring an IF interface at 70MHz ±18MHz or 140MHz ±36MHz. Depending on the system requirements and budgets these systems can be tailored to every applications' needs.

	<b>Passive 1+1</b>	<b>Hybrid 1+1</b>	<b>Hybrid 2+1</b>	<b>Active 1+1</b>	<b>Active 2+1</b>
<b>Path Loss *</b>	8dB	5dB	8dB	3dB	5dB
<b>Control</b>	Internal to converter	Internal to converter	Internal to converter	External	External

\*Does not include converter gain.